

STANDARD NOTES FOR PET BOTTLE

1. ALL DIMENSIONS IN MILIMETERS.

2. FULL SCALE UNLESS NOTED.

3. FOR BOTTLES 72 HOURS AFTER MANUFACTURED

THE FOLLOWING TOLERANCES APPLY:

NOMINAL CAPACITY:	HEIGHT	DIAMETER
0 to 500ml	± 0,65	± 0,55
501 to 1490ml	± 0,85	± 0,70
1491 to 3000ml	± 1,20	± 0,85
3001 to 5000ml	± 1,80	± 1,80

4. FOR AS DELIVERED BOTTLES.

THE FOLLOWING TOLERANCES APPLY (EXCEPT WHERE NOTED):

NOMINAL CAPACITY	HEIGHT	DIAMETER
0 to 500ml	+0,60 -1,25	+0,50-0,65
501 to 1490ml	+0,75 -1,60	+0,60 -0,85
1491 to 3000ml	+1,20 -1,50	+0,75 -1,00

5. FOR AS DELIVERED BOTTLES.

THE FOLLOWING CAPACITY TOLERANCES APPLY (EXCEPT WHERE NOTED):

NOMINAL CAPACITY	INDIVIDUAL	AVERAGE
0 to 1000ml	± 1,25% of nominal	± 0,75% of nominal
> 1000	± 1,00% of nominal	± 1,50% of nominal

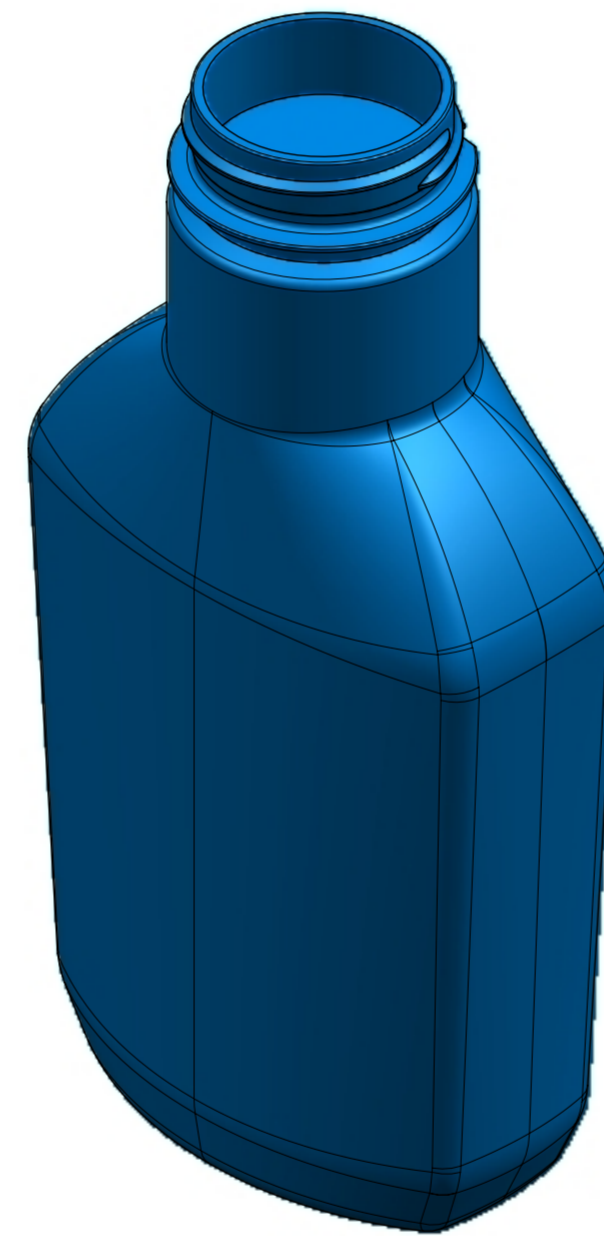
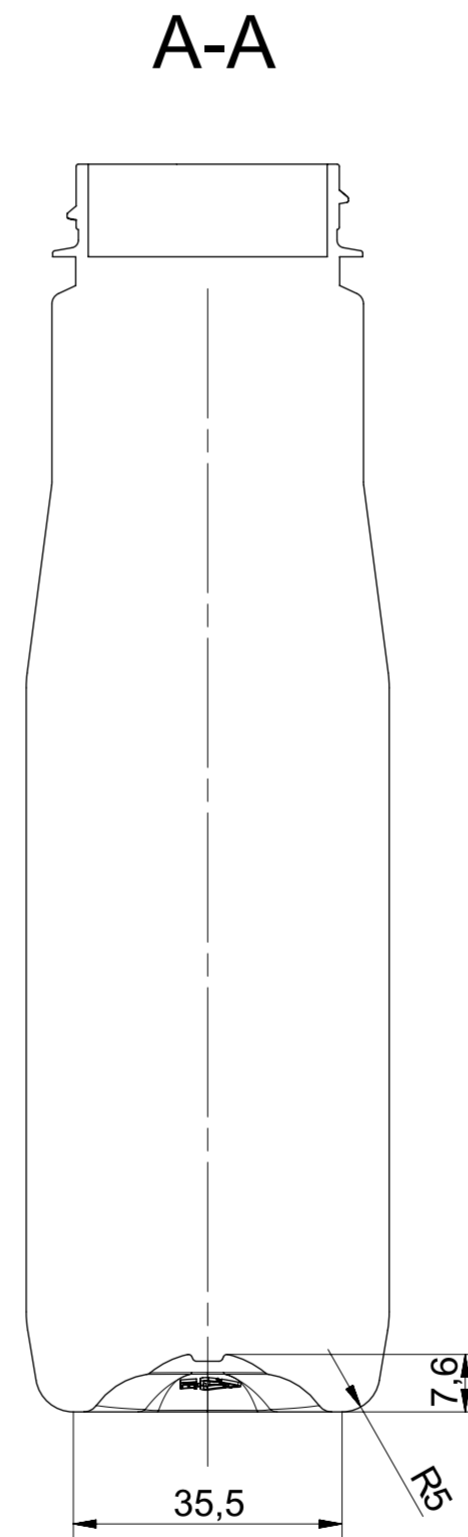
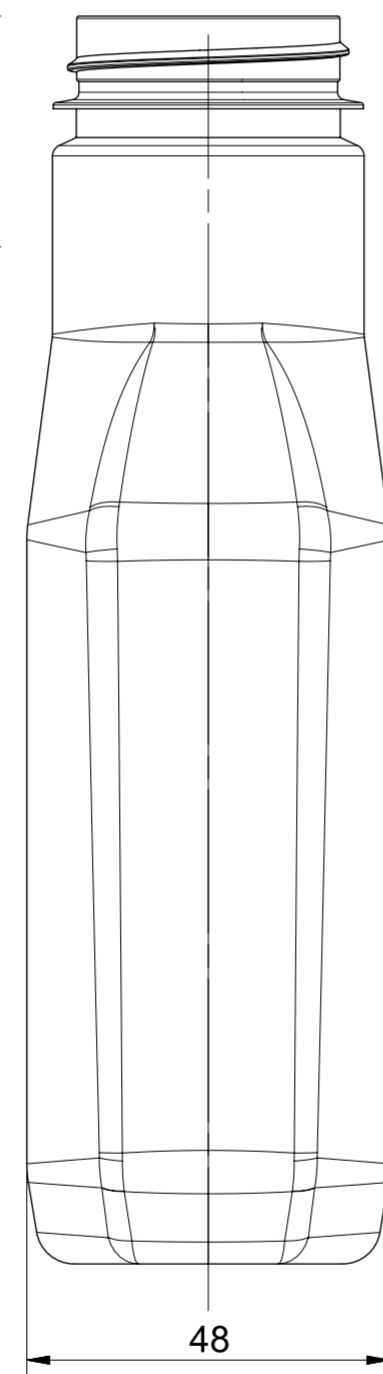
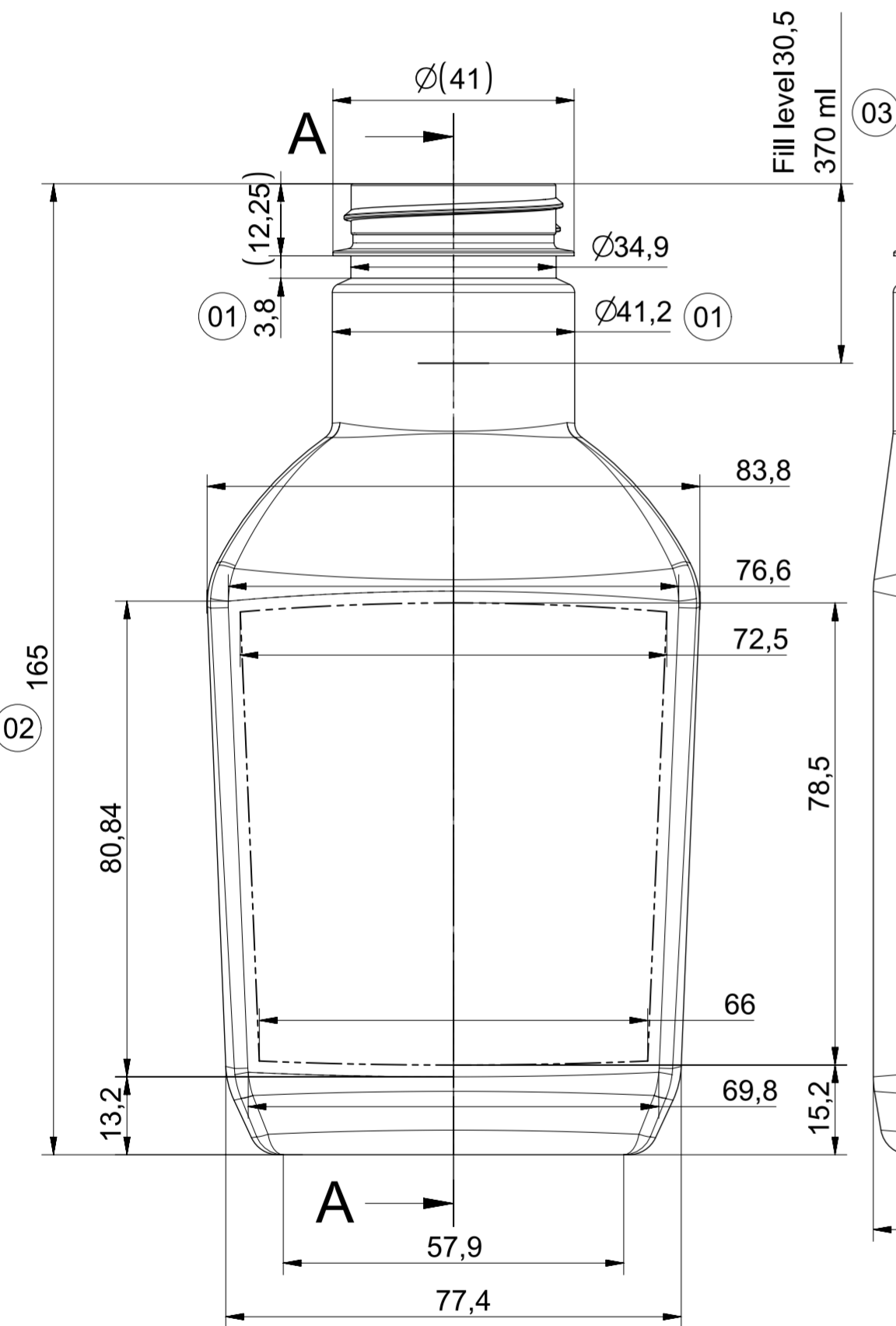
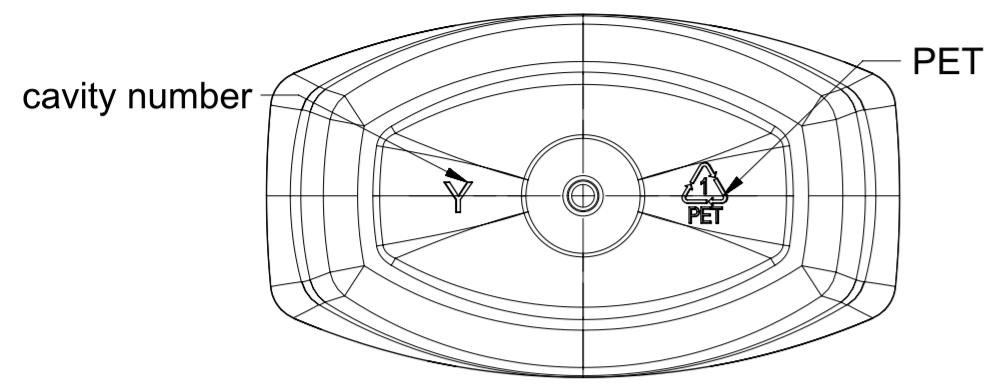

MEASUREMENT POINT			PREFORM 1	PREFORM 2
FILL POINT CAPACITY	nominal	(ml)	370	
FILL POINT CAPACITY	calc	(ml)	370	
BRIMFULL CAPACITY	calc	(ml)	401	03
PREFORM WEIGHT		(g)	28	

03	Dopasowanie poziomu nalewu	7.01.2019	A. Gońka
02	Zmiana wysokości butelki	7.01.2019	A. Gońka
01	Zmiana średnicy i zmiana wysokości szyjki	7.01.2019	A. Gońka
No	Modification	Date	Signature

Diameter	Label length	Surface area	Neck	Base volume	Gravity center

Drawn by: A. Gońka	Signature:	Date: 07.01.2019	Description: Butelka 370 ml
Approved:	Signature:	Date:	

		Number b1706037_1	
UŁ. KARTUSKA 267 80-125 GDAŃSK POLSKA	TEL: (+48 58) 302 34 32 FAX: (+48 58) 302 96 93 office@lonza.com.pl www.lonza.com.pl	Material PET 1.335 g/cm3	Scale: 1:1
		Sheet size: A2	

THIS DRAWING IS THE PROPERTY OF THE LONZAPET SP. Z O.O. COMPANY AND IS NOT TO BE USED OR REPRODUCED WITHOUT WRITTEN PERMISSION

N:\projekty\butelki_projekty\b1706037\b1706037_1\b1706037_1.prt